

# Range *clear water*

Water pressure booster - Regulation - Anti water hammer

## Hydrofort

Flanged outlet - 500 to 2000 L

The **Hydrofort** vessel ensures that the pressure in a system is maintained following low consumption or leaks (also limits the number of pump start per hour).

MANUFACTURING TO CODAP



### PAINT

**Internal.** Anti rust glycerophthalic primer, colour red ocre, thickness 30 microns.  
**External.** One coat acrylic urethane resin, colour orange, thickness 30 microns.



### BLADDER

Interchangeable food quality butyl.



### WARRANTY

Not including parts subject to wear and tear and subject to use under normal conditions.



### PACKING

Buble pack for the vessels, cardboard box for the various equipment and/or accessories.

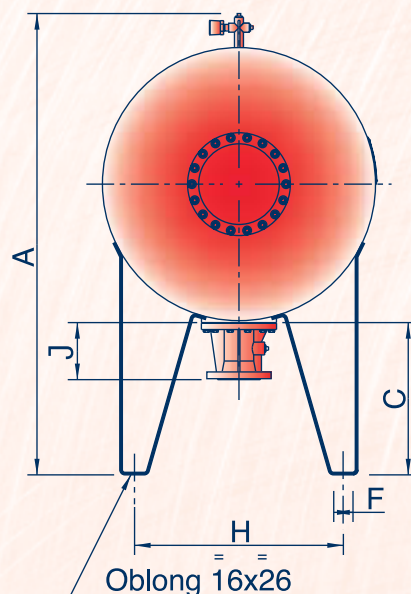
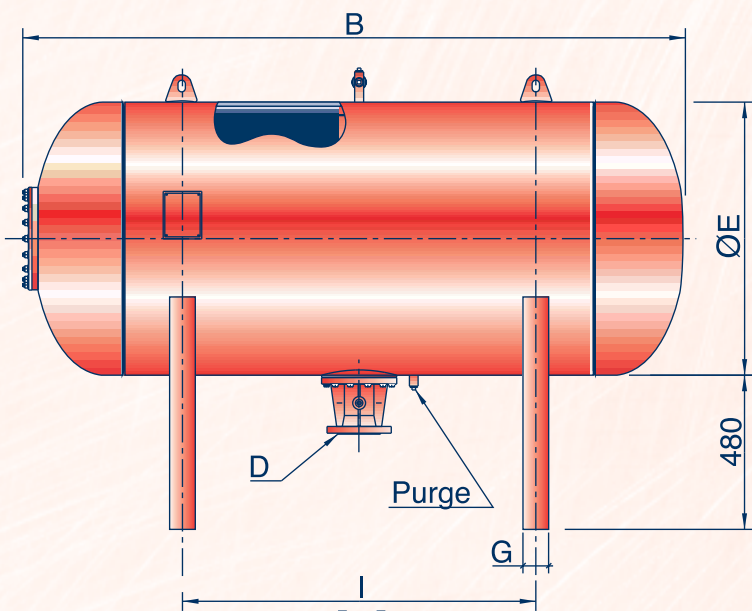

View from underside

Outlet D	J	Wt (KG)
DN50	180	12
DN80	176	14
DN100	167	12
DN125	167	13
DN150	170	14

The dimension shown are indicative and can be modified without warning.

The height of the outlet from the ground = C - J

## Range 25/37.5 bar

Code	Vol.	A (mm)	B	C	Ø E (mm)	F	G	H	I	Weight without outlet (kg)
HF-500-25/37.5-H	500	1195	1798	475	630	60	80	490	1000	294
HF-750-25/37.5-H	750	1415	1607	475	850	60	80	650	800	434
HF-1000-25/37.5-H	1000	1415	2107	475	850	60	80	650	1100	538
HF-1500-25/37.5-H	1500	1565	2191	475	1000	80	100	750	1200	780
HF-2000-25/37.5-H	2000	1565	2891	475	1000	80	100	750	1800	994