

Range *clear water*

Water pressure booster - Regulation - Anti water hammer

Hydrofort

Bottom outlet - 100 to 2000 L

The **Hydrofort** vessel ensures that the pressure in a system is maintained following low consumption or leaks (also limits the number of pump start per hour).

MANUFACTURING TO CODAP



PAINT

Internal. Anti rust glycerophthalic primer, colour red ocre, thickness 30 microns.
External. One coat acrylic urethane resin, colour orange, thickness 30 microns.



BLADDER

Interchangeable food quality butyl.



WARRANTY

Not including parts subject to wear and tear and subject to use under normal conditions.



PACKING

Bubble pack for the vessels, cardboard box for the various equipment and/or accessories.

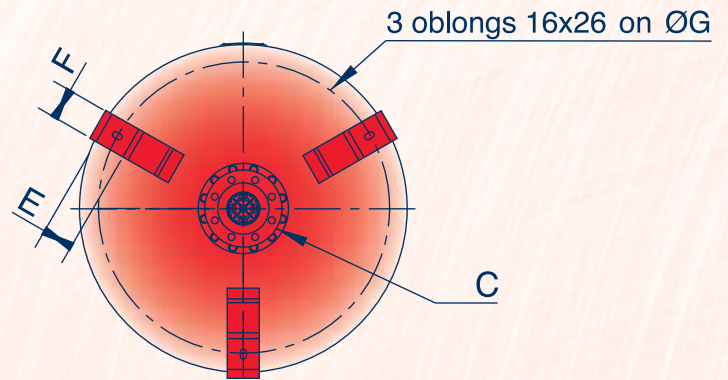
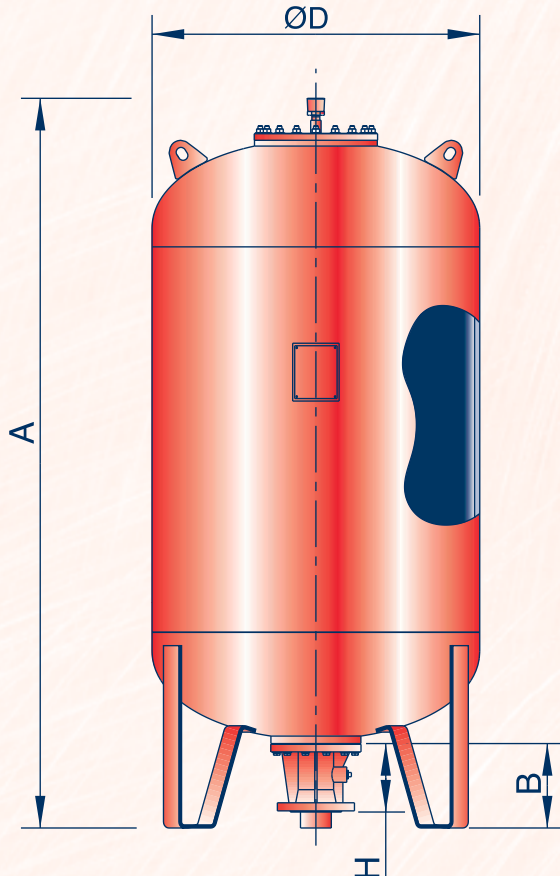

View from underside

Outlet C	H	Wt (KG)
DN50	180	12
DN80	176	14
DN100	167	12
DN125	167	13
DN150	170	14

The height of the outlet from the ground = B - H

Range 16/24 bar

The dimension shown are indicative and can be modified without warning.

Code	Vol.	A (mm)	B	Ø D	E (mm)	F	G	Weight without outlet (kg)
HF-100-16/24-VF	100	791	220	630	54	50	560	78
HF-200-16/24-VF	200	1101	220	630	54	50	560	110
HF-300-16/24-VF	300	1450	220	630	54	50	560	148
HF-500-16/24-VF	500	2076	220	630	54	50	560	210
HF-750-16/24-VF	750	1893	220	850	80	80	755	338
HF-1000-16/24-VF	1000	2393	220	850	80	80	755	427
HF-1500-16/24-VF	1500	2472	215	1000	80	100	905	601
HF-2000-16/24-VF	2000	3178	215	1000	80	100	905	782