

Range *clear water*

Water pressure booster - Regulation - Anti water hammer

Hydrofort

Bottom outlet - 100 to 2000 L

The **Hydrofort** vessel ensures that the pressure in a system is maintained following low consumption or leaks (also limits the number of pump start per hour).

MANUFACTURING TO CODAP



PAINT

Internal. Anti rust glycerophthalic primer, colour red ocre, thickness 30 microns.
External. One coat acrylic urethane resin, colour orange, thickness 30 microns.



BLADDER

Interchangeable food quality butyl.



WARRANTY

Not including parts subject to wear and tear and subject to use under normal conditions.



PACKING

Bubble pack for the vessels, cardboard box for the various equipment and/or accessories.

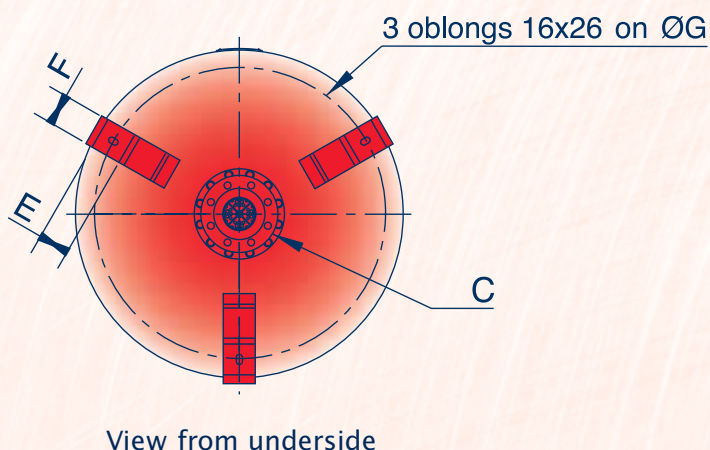
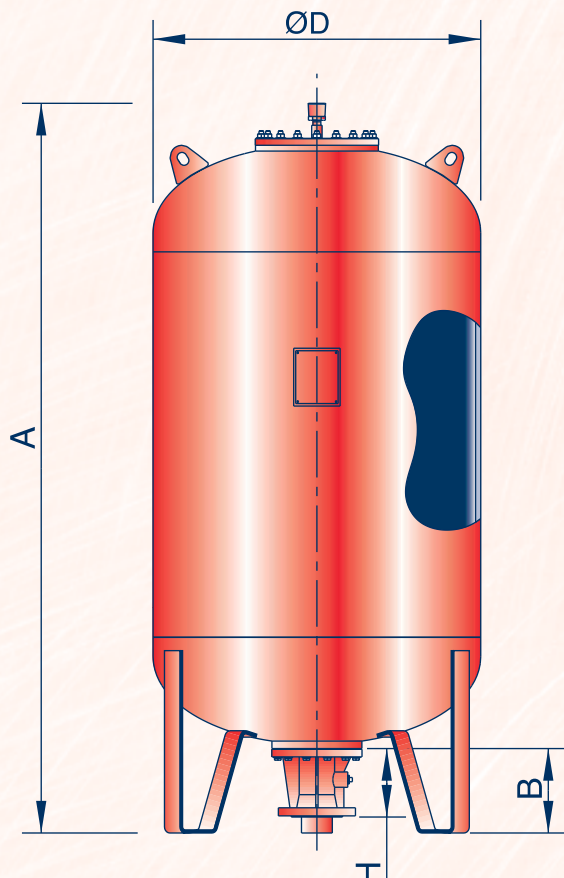

View from underside

Outlet C	H	Wt (KG)
DN50	180	12
DN80	176	14
DN100	167	12
DN125	167	13
DN150	170	14

The height of the outlet from the ground = B - H

Range 10/15 bar

The dimension shown are indicative and can be modified without warning.

Code	Vol.	A (mm)	B	Ø D	E (mm)	F	G	Weight without outlet (kg)
HF-100-10/15-VF	100	783	220	630	54	50	560	59
HF-200-10/15-VF	200	1093	220	630	54	50	560	81
HF-300-10/15-VF	300	1418	220	630	54	50	560	104
HF-500-10/15-VF	500	2068	220	630	54	50	560	151
HF-750-10/15-VF	750	1863	215	850	80	80	755	237
HF-1000-10/15-VF	1000	2363	215	850	80	80	755	306
HF-1500-10/15-VF	1500	2414	215	1000	80	100	905	408
HF-2000-10/15-VF	2000	3114	215	1000	80	100	905	521