

# Range *clear water*

Water pressure booster - Regulation - Anti water hammer

## Hydrochoc

Lateral outlet - 500 to 2000 L

The **Hydrochoc** surge vessel is a hydropneumatic bladder accumulator which dampens water hammer in transients.

MANUFACTURING TO CODAP



### PAINT

**Internal.** Anti rust glycerophthalic primer, colour red ocre, thickness 30 microns.

**External.** One coast acrylic urethane resin, colour orange, thickness 30 microns.



### BLADDER

Interchangeable food quality butyl.



### WARRANTY

Not including parts subject to wear and subject to use under normal conditions.



### PACKING

Buble pack for the vessels, cardboard box for the various equipment and/or accessories.

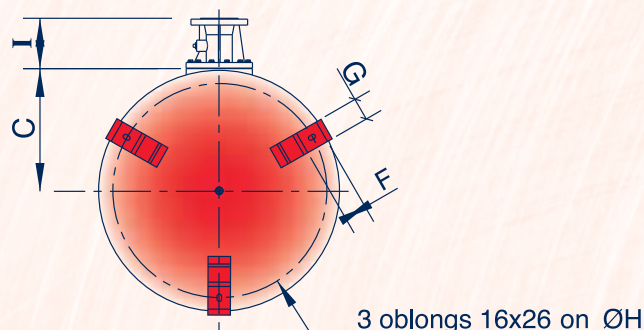
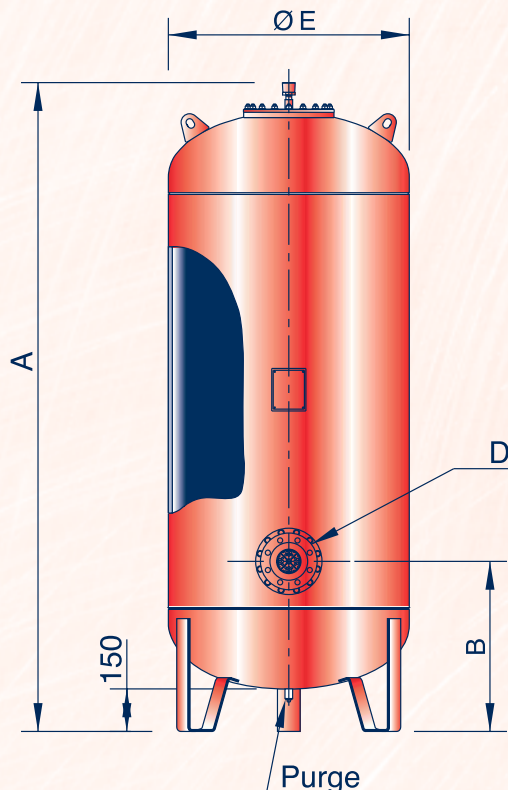

View from underside

Outlet D	I	Wt (KG)
DN50	180	12
DN80	176	14
DN100	167	12
DN125	167	13
DN150	170	14

The dimension shown are indicative and can be modified without warning.

## Range 16/24 bar

Code	Vol.	A (mm)	B	C	Ø E (mm)	F	G	H	Weight without outlet (kg)
BS-500-16/24-V	500	1996	550	322	630	54	50	560	209
BS-750-16/24-V	750	1816	600	432	850	80	80	755	340
BS-1000-16/24-V	1000	2316	600	432	850	80	80	755	425
BS-1500-16/24-V	1500	2398	630	507	1000	80	100	905	597
BS-2000-16/24-V	2000	3098	630	507	1000	80	100	905	778