

Range *clear water*

Water pressure booster - Regulation - Anti water hammer

Hydrochoc

With non return valve - **100 to 2000 L**

The **Hydrochoc** surge vessel is a hydropneumatic bladder accumulator which dampens water hammer in transients.

MANUFACTURING TO CODAP



PAINT

Internal. Anti rust glycerophthalic primer, colour red ocre, thickness 30 microns.

External. One coast acrylic urethane resin, colour orange, thickness 30 microns.



BLADDER

Interchangeable food quality butyl.



WARRANTY

Not including parts subject to wear and tear and subject to use under normal conditions.



PACKING

Buble pack for the vessels, cardboard box for the various equipment and/or accessories.

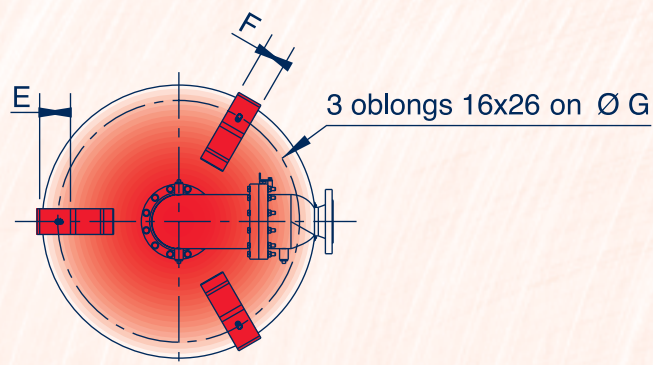
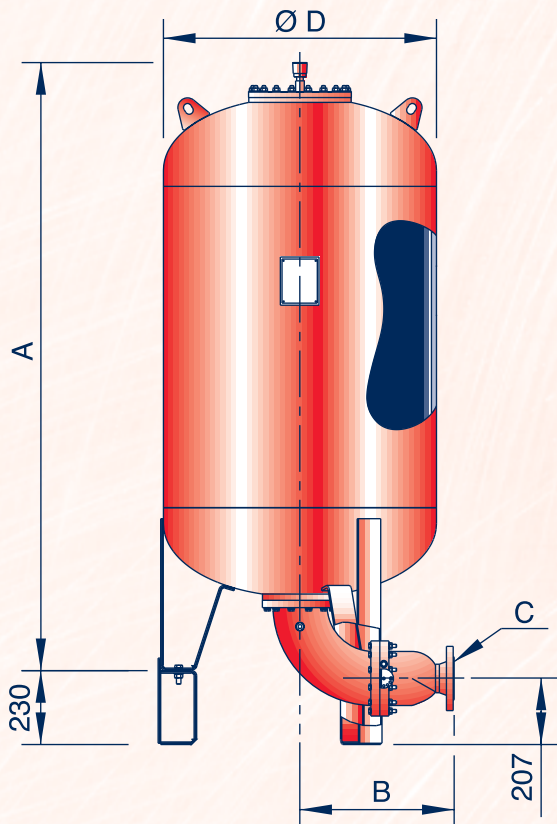

View from underside

Outlet C	B	Wt (KG)
DN50	476	32
DN80	480	35
DN100	460	34
DN125	450	35
DN150	457	37

The dimension shown are indicative and can be modified without warning.

Range 10/15 bar

Code	Vol.	A (mm)	Ø D (mm)	E	F	G	Weight without outlet (kg)
HC-100-10/15-VF	100	783	630	54	50	560	71
HC-200-10/15-VF	200	1093	630	54	50	560	93
HC-300-10/15-VF	300	1418	630	54	50	560	116
HC-500-10/15-VF	500	2068	630	54	50	560	163
HC-750-10/15-VF	750	1863	850	80	80	755	261
HC-1000-10/15-VF	1000	2363	850	80	80	755	330
HC-1500-10/15-VF	1500	2414	1000	80	100	905	444
HC-2000-10/15-VF	2000	3114	1000	80	100	905	557