

# Range waste water

Anti water hammer

MANUFACTURING TO CODAP



## ARAA

«T» outlet - 500 to 2000 L

The **Hydrochoc waste water** surge vessel with automatic air regulation operates not only as a surge wessel but also as a balancing chimney, without compressor or bladder. Designed for heavily charged or fibrous liquids, it is perfectly adapted to protect flat pipelines often encountered in waste water systems.



### PAINT

**Internal.** Epoxy paint without solvent, colour white, thickness 100 microns.  
**External.** Polyurethane lacquer, colour yellow and anti corrosion polyurethane finishing, thickness 50 microns.



### WARRANTY

Not including parts subject to wear an tear and subject to use under normal conditions.



### PACKING

Buble pack for the vessels.

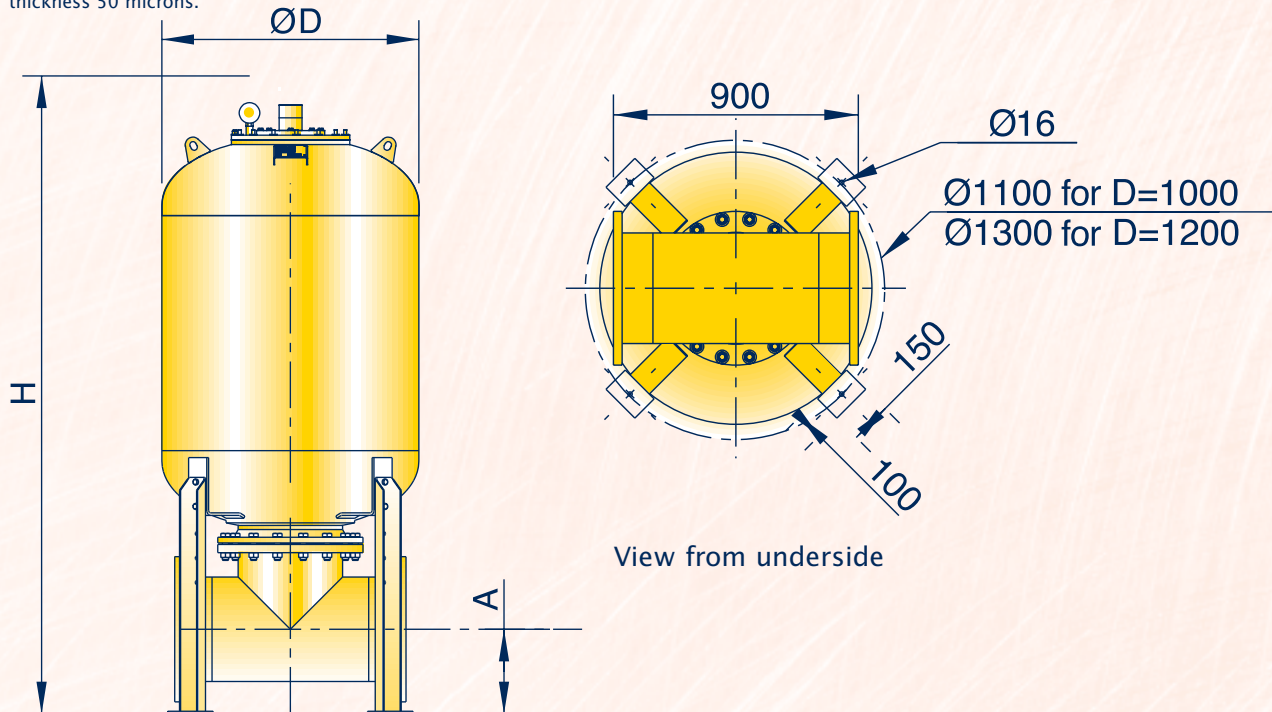

### Range 4/6 bar and 7/10,5 bar

The dimension shown are indicative and can be modified without warning.

DN	$\varnothing D = 1000$						$\varnothing D = 1200$				A
	500 Liters		750 Liters		1000 Liters		1500 Liters		2000 Liters		
	H	Wght	H	Wght	H	Wght	H	Wght	H	Wght	
100	1538	407	1858	454	2143	504	2364	586	2764	656	212
125	1538	414	1858	461	2143	511	2364	593	2764	663	193
150	1538	418	1858	465	2143	515	2364	597	2764	667	174
200	1633	434	1953	481	2288	531	2459	613	2859	683	234
250	1633	437	1953	484	2288	534	2459	616	2859	686	215
300	1834	444	2154	491	2489	541	2660	623	3060	693	378
350	1834	472	2154	519	2489	569	2660	650	3060	720	352
400	1834	488	2154	535	2489	585	2660	667	3060	737	328