

Range waste water

Anti water hammer

MANUFACTURING TO CODAP



ARAA

«T» outlet - 150 to 300 L

The **Hydrochoc waste water** surge vessel with automatic air regulation operates not only as a surge wessel but also as a balancing chimney, without compressor or bladder. Designed for heavily charged or fibrous liquids, it is perfectly adapted to protect flat pipelines often encountered in waste water systems.



PAINT

Internal. Epoxy paint without solvent, colour white, thickness 100 microns.

External. Polyurethane lacquer, colour yellow and anti corrosion polyurethane finishing, thickness 50 microns.



WARRANTY

Not including parts subject to wear and tear and subject to use under normal conditions.



PACKING

Buble pack for the vessels.

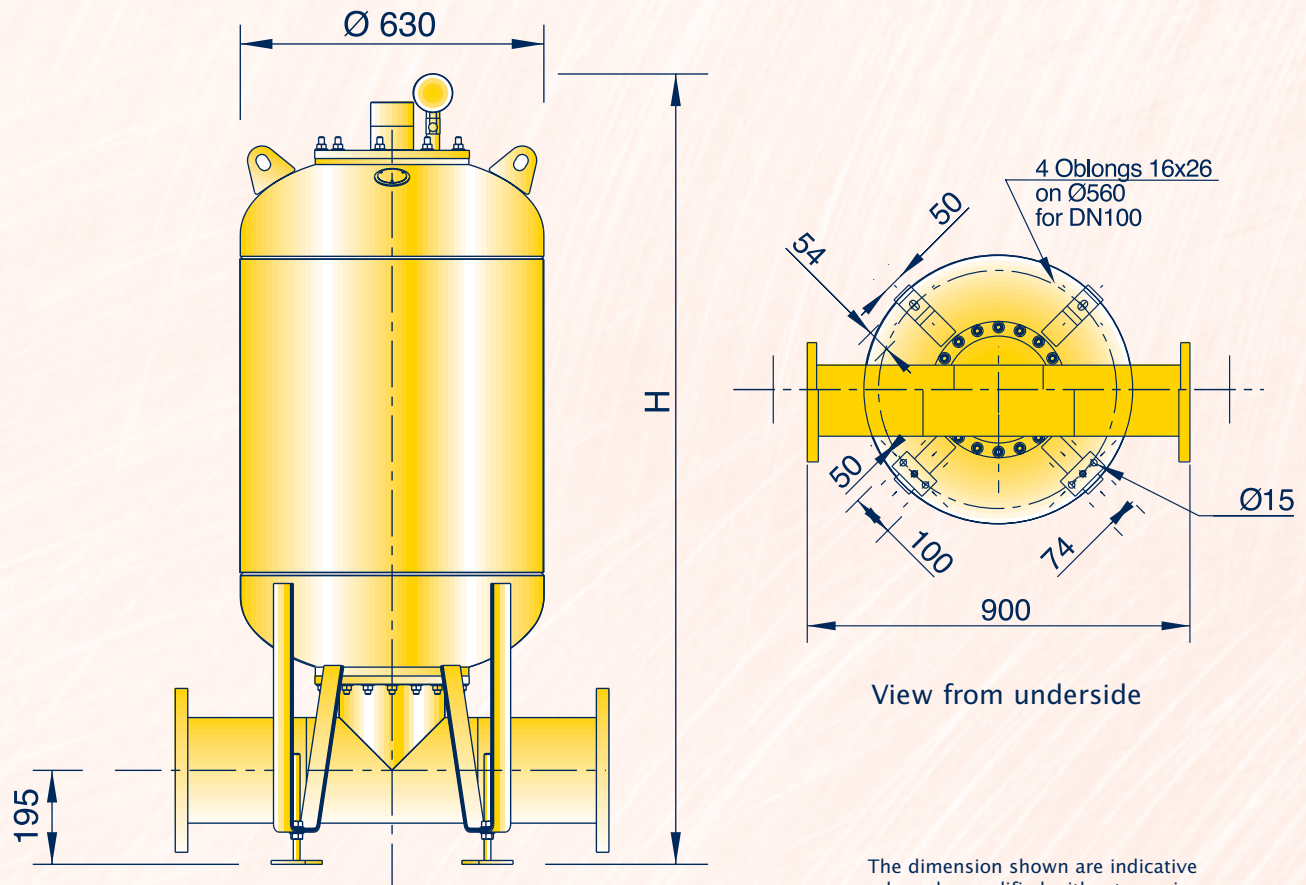

The dimension shown are indicative and can be modified without warning.

Range 4/6 bar and 7/10,5 bar

DN	Vol.	H	Weight without outlet (kg)
100	150	1205	167
125	150	1223	173
150	150	1237	177
200	150	1190	193
100	300	1655	195
125	300	1673	201
150	300	1687	205
200	300	1722	221